

## Technical Data – IR<sup>3</sup> Flame Sensor

### Mechanical

Housing Material:	Stainless Steel (316)
Housing Colour:	Natural
Dimensions:	See Fig. 9
Weight:	6kg
Cable Gland Entries:	1 x 25mm & 1 x 20mm

### Electrical

Sensor Supply: Terminals 1 & 2	Voltage Current	14 to 30Vdc See DIL switch settings
Test Signal Voltage:		14 to 30Vdc
Power Up Time:		2 seconds max.
Relay Contact Ratings: RL1 Terminal 5 & 6 RL2 Terminal 7 & 8 Resistive Loads Only	Current Voltage Power	1.0Amp. Max. 50Vdc. Max. 30W Max.

### Performance

Range: (See EN54-10)	- Class 1	0.1m <sup>2</sup> n-heptane at 25m 0.2m <sup>2</sup> n-heptane at 35m 0.4m <sup>2</sup> n-heptane at 45m
Sensitivity Setting	- Class 3	0.1m <sup>2</sup> n-heptane at 12m
Field of View:		90° min. Cone
Spectral Response:	IR	0.75 to 2.7µm
Sensitivity: (See EN54-10)		High = Class 1 Low = Class 3

### Environmental

ATEX Marking	II 2GD Ex d IIC T4 Gb Ex tb IIIC T135°C Db IP66 A21
IECEX Marking	Ex d IIC T4 Gb Ex tb IIIC T135°C Db IP66 A21
Operating Temperature:	- 10°C to +55°C Sensor Limit
Storage Temperature:	- 20°C to +65°C
Relative Humidity:	95% Non condensing
IP Rating:	IP66
External Water Pressure:	9.7bar (140psi) for 30mins.
EMC Immunity / Emissions:	EN 61000-6-1, EN61000-6-2 EN 61000-6-3, EN61000-6-4 EN 50130-4, EN 55022

See Flame Detector Installation Guide for more detail.

### Product Approvals

Baseefa ATEX Certificate No.	Baseefa08ATEX0270
Baseefa IECEX Certificate No.	IECEX BAS 08.0073
Designed to meet	EN54-10

### Stainless Steel Mounting Bracket - Option

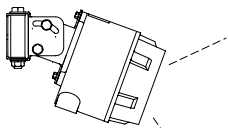
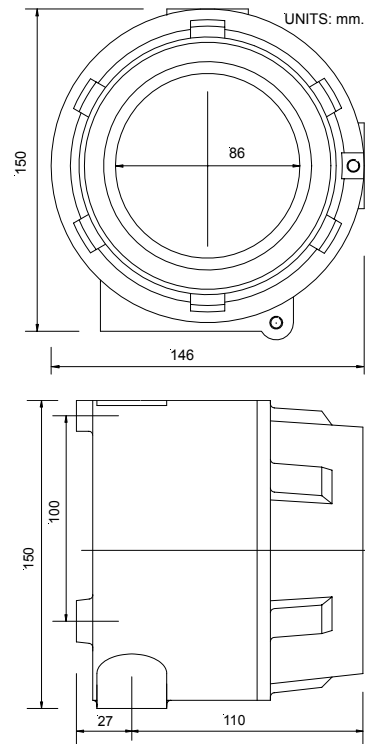

Fig. 8 Adjustable Mounting Part number: 007295

- BS EN 54-10:2002 Fire detector and fire alarm systems; Part 10: Flame detectors – point detectors.
- Although this sensor is not affected by normal daylight conditions, sunlight should be prevented from falling directly on to the IR optics.



FIXING HOLES 2 X TAPPED M6 (8 DEEP)

Fig. 9 Dimensions – IR<sup>3</sup> Flame Sensor

Selectable Options	DIL Switch Settings	
Relay RL2 Function:	1	2
RL2 Off	0	0
RL2 Off	1	0
IR fire or pre-alarm	0	1
Fault (Enlarged if OK)	1	~ 1
Quiescent & Alarm Currents:	3	4
3/9mA RL1 Only, 4/8/14mA RL2 & RL1	0	0
4-20mA, 4/20mA, No Relays	1	0
/ Or 8-20mA, 8/20mA, & Relays	0	1
- Proportional 8/28mA, & Relays	1	~ 1
Output Mode:	5	
Non-latching (-)	0	
Latching (/)	~1	
Response Time:	6	7
Slowest ≈ 8s	0	0
Medium ≈ 4s	1	~ 0
Fast ≈ 2s	0	1
Very Fast ≈ 1s	1	1
Sensitivity:	8	
Low (Class 3)	0	
High (Class 1)	~ 1	

Factory settings ~

## 016549 STAINLESS STEEL FLAMEPROOF IR<sup>3</sup> FLAME SENSOR

### Features

- ATEX & IECEX certified:  
II 2GD Ex d IIC T4 Gb  
Ex tb IIIC T135°C Db IP66 A21  
[Zones 1, 21, 2 and 22]
- Stainless Steel (316) Housing
- Class 1 Sensitivity to EN54-10  
Detects 0.1m<sup>2</sup> fire @ 25m
- Excellent Optical Interference Immunity
- Selectable Output Options  
Conventional 2 wire  
4-20mA  
Latching or Non-latching  
Relay Contacts;  
Fire/Fault, Pre-alarm
- Optical Self Test
- Low Power Consumption
- CE Marked

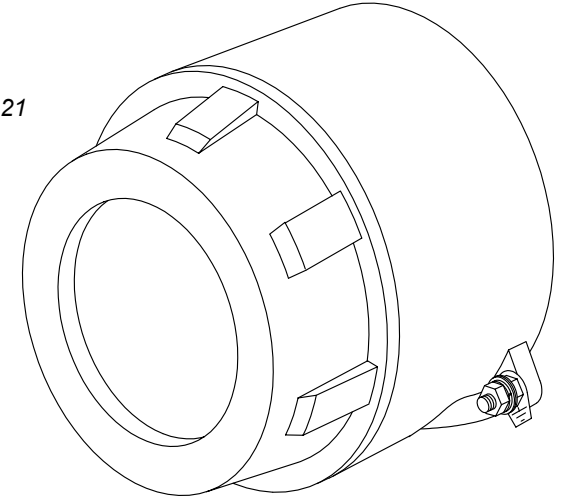

### Operating Principles

The sensor responds to low-frequency (1 to 15 Hz) flickering IR radiation emitted from flames during combustion.

IR flame flicker techniques enable the sensor to operate through a layer of oil, dust, water vapour, or ice.

Most IR flame sensors respond to 4.3µm light, emitted by hydrocarbon flames. By responding to 1.0 to 2.7µm light emissions from fires almost all flickering flames can be detected. Gas fires not visible to the naked eye e.g. hydrogen may also be detected.

The triple IR photoelectric detectors (IR<sup>3</sup>), responding to neighbouring IR wavelengths, enable it to discriminate between flames and spurious sources of IR radiation.

The combination of filters and signal processing allows the sensor to be used with a very low risk of false alarms in difficult situations characterised by factors such as flickering sunlight.

### Electrical Connections

The sensor can be connected to a two-wire circuit supplying 14V to 30V dc. The sensor is connected to the supply via terminals 1(+IN) and 2(-IN) under the front terminal cover. Connections to the sensor are polarity sensitive.

A remote sensor optical test input is available on terminals 3(+R) for +IN and 4(-R) 0V. When a 14V to 30V dc supply is applied to this input IR test sources activate within the sensor and a flame-detected state will be outputted. See Fig. 1

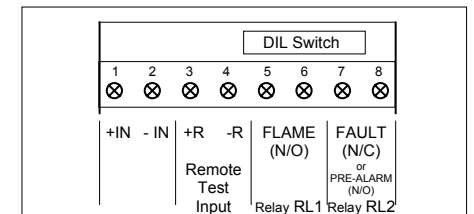
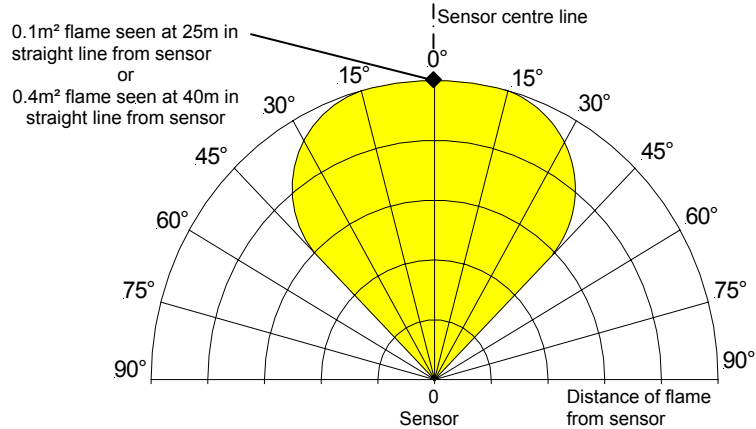

Fig. 1 Connection Terminals (Front Cover Removed)

## Flame Detection Characteristics

The flame sensor should be positioned at the perimeter of the room, pointing directly at the area of the anticipated flame or at the centre of the area to be protected. The further away the flame is from the sensor the larger the fire has to be, with detection beyond 50m becoming unpredictable. An n-heptane flame with a base area of 0.1m<sup>2</sup> will be detected on the sensor centre line at 25m, with the sensitivity set high for class 1 performance. See Fig. 2

If the sensitivity switch were set to low, for class 3 performance, the same 0.1m<sup>2</sup> flame would be detected at 12m.



**Fig. 2** Sensor horizontal angle of view and range for n-heptane fire (yellow sooty flame) - IR<sup>3</sup> Flame Sensor, sensitivity set high for class 1 performance

The polar diagrams show that the sensor sensitivity is at its greatest along the central axis. The variation in relative range against viewing angle is shown as a proportion of peak performance. The diagrams are sections through the sensors conical field of view.

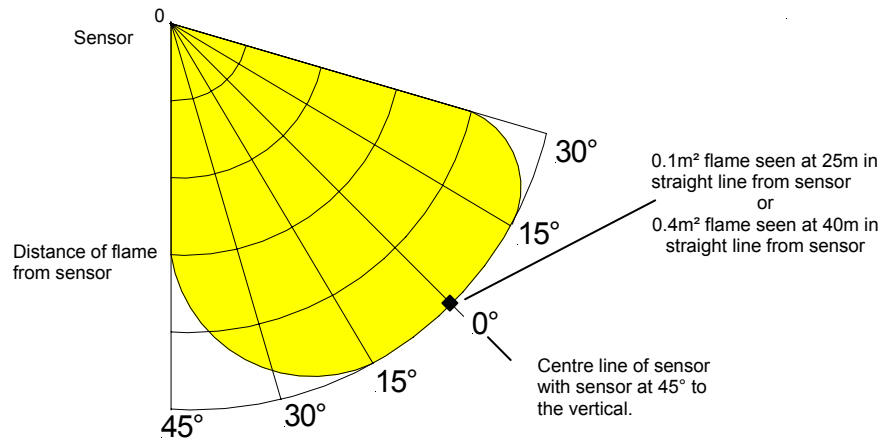

**Fig. 3** Sensor vertical viewing angle and range - IR<sup>3</sup> Flame Sensor, sensitivity set high for class 1 performance

## Alarm Current Output Values (Latching)

When the sensor detects a flame the sensor supply current value (4-20mA or 8-28mA) will increase.

The sensor is shipped with the internal DIL switch (5) set to give a latching alarm current. Normally the current required by the sensor is 4mA or 8mA at 24Vdc with no flame in view. When a flame is in view, the supply current value will increase to 20mA or 28mA, the fire relay RL1 will energise and red fire LED will illuminate.

The supply to the sensor has to be broken in order to reset the sensor.

Values below 3.0mA are an indication of a fault conditions. See Fig. 4

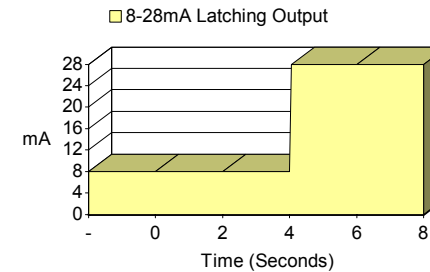

**Fig. 4** Typical Response on seeing Flame - IR<sup>3</sup> Flame Sensor

Once illuminated the red Fire LED and output value are held for 5 seconds after the last flame has been seen, after which the output value decrements back to 4 or 8mA. See Fig. 6

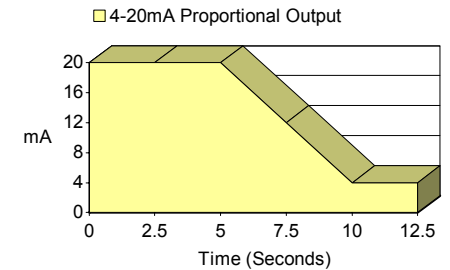

**Fig. 6** Typical Response after last Flame seen - IR<sup>3</sup> Flame Sensor

## Proportional Output Values (Non-latching)

When the sensor sees any flame flicker the proportional values of (4-20mA or 8-20mA) will increase.

The sensor is set to give a proportional value of 4mA or 8mA with no flame in view. The value increments when flame flicker pulses are seen.

With an output value approaching 20mA the fire LED will illuminate.

Values below 3.0mA are an indication of a fault conditions. See Fig. 5

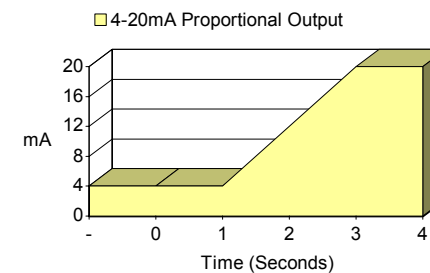

**Fig. 5** Typical Response on seeing Flame - IR<sup>3</sup> Flame Sensor

Proportional output values between 4 or 8mA and 20mA can be used to provide an early warning of fire. These values hold only for 3 seconds from the last flame sighting. See Fig. 7

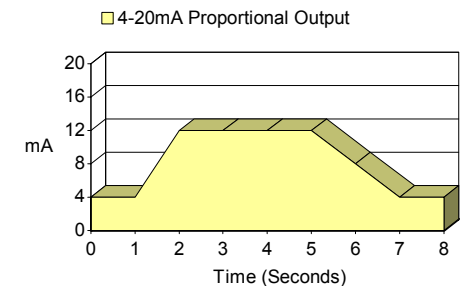

**Fig. 7** Typical Response to Burst of Flame - IR<sup>3</sup> Flame Sensor