

Flameproof – (Ex d) Flame Detector Installation Guide

General

This Installation Guide gives information on the Flameproof (Ex d) version of the flame detectors that have been approved by Baseefa. The requirements of the European Community Directive 94/9/EC, the Atmosphere Explosives ATEX Directive have been met. The approval has been accessed to the following European Standards EN60079-0, EN 60079-1 and EN 60079-26.

Also the flame detector has been accessed and approved to IECEx requirements.

The detector enclosures are certified category  II 2 G D, Ex d IIC T4 Gb

Ex tb IIIC T135°C Db IP66 A21

Tamb = -40°C to +125°C

The range comprises dual infra-red (IR²), triple infra-red (IR³) and UV/IR² flame detectors. The detector housings are available in copper free aluminium alloy (LM25) and stainless steel (316).

The guide also provides information on Flameproof (type'd') enclosures, the application, maintenance, installation and adjustments of the detectors. Reference to other individual detector publications can be made for more information on none Flameproof issues. These publications are available on request.

Introduction to Flameproof Enclosures

There are many places where an explosive mixture of air and gas or vapour is or may be present, intermittently or as a result of an accident. These are defined as hazardous areas by EN 60079-0 (formally EN 50014), Electrical apparatus for explosive gas atmospheres – General requirements.

Hazardous areas are common in petroleum and chemical engineering plants and in factories processing and storing gases, solvents, paints and other volatile substances.

Electrical equipment for use in these areas needs to be designed so that it cannot ignite an explosive mixture, not only in normal operation but also in fault conditions. There are a number of methods available to achieve this – oil immersion, pressurised apparatus and powder filling, for example, but the two most common used are intrinsic safety and flameproof enclosures.

Flameproof equipment is contained in a box so strong that an internal explosion will neither damage the box nor be transmitted outside the box. The surface must remain cool enough not to ignite the explosive mixture.

When flameproof equipment is interconnected, flameproof wiring must be used. This method is most valuable when high power levels are unavoidable but it is not acceptable for areas in which an explosive gas/air mixture may be continuously present or present for long periods.

For this reason these flame detectors are made intrinsically safe rather than flameproof. Intrinsically safe equipment operates at such low power and with such small amounts of stored energy that it is incapable of causing ignition:

- In normal conditions
- With a single fault (for **ib** type of protection code)
- With any combination of two faults (for **ia** type of protection code)

In any of these conditions every component must remain cool enough not to ignite gases for which it is approved. See Table 4

Classification of Hazardous Areas

EN 60079-0 (formally EN50014) states that electrical apparatus for potentially explosive atmospheres is divided into:

- Gas Group I: Electrical apparatus for mines susceptible to fire damp;
- Gas Group II: Electrical apparatus for places with a potentially explosive atmosphere, other than mines susceptible to fire damp.

These flame detectors are designed to meet the requirements of Group II apparatus. For the type of protection “d” Flameproof, Group II is subdivided into Equipment Categories, Type of Explosive Atmosphere (Table 1), Type of Protection Code (Table 2), Temperature Class (Table 3) and Gas Group (Table 4).

Exd System Drawing

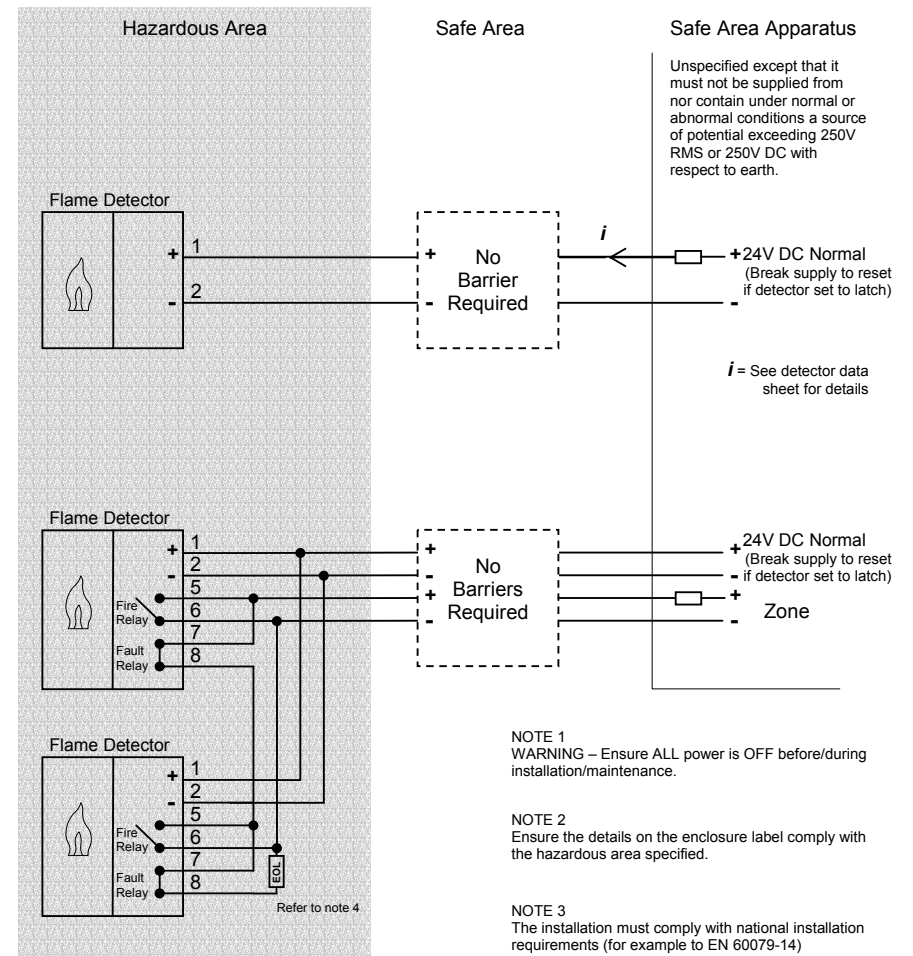

NOTE 1
WARNING – Ensure ALL power is OFF before/during installation/maintenance.

NOTE 2
Ensure the details on the enclosure label comply with the hazardous area specified.

NOTE 3
The installation must comply with national installation requirements (for example to EN 60079-14)

NOTE 4
If required a loading resistor or end of line device (EOL) can be connected between the detector terminals of any circuit. The total power dissipation and temperature classes within the enclosure must not be exceeded, 30W – T4.

NOTE 5
The 24Vdc supply line to the detectors should be fused at 1A.

Enclosure with Front Cover Removed

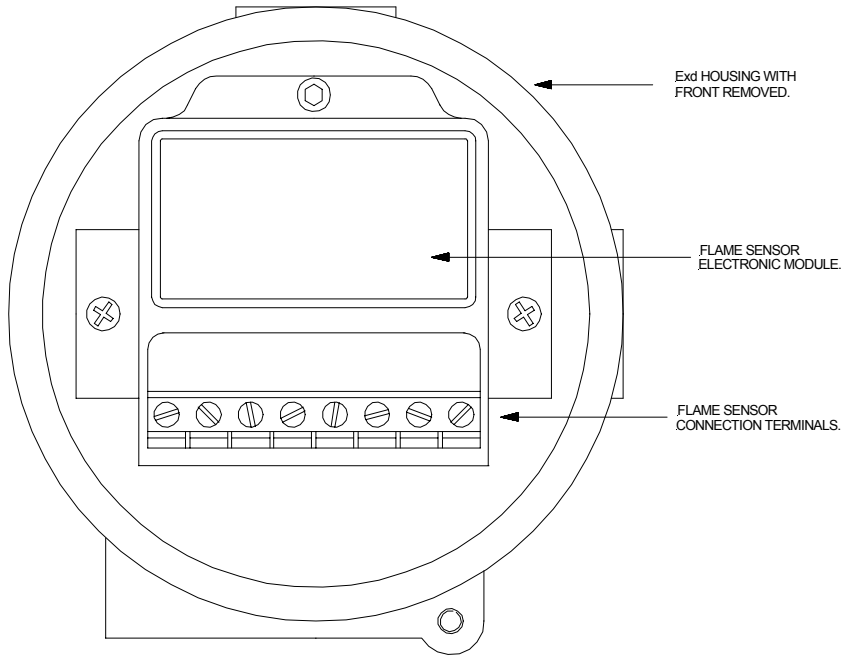

Equipment Markings

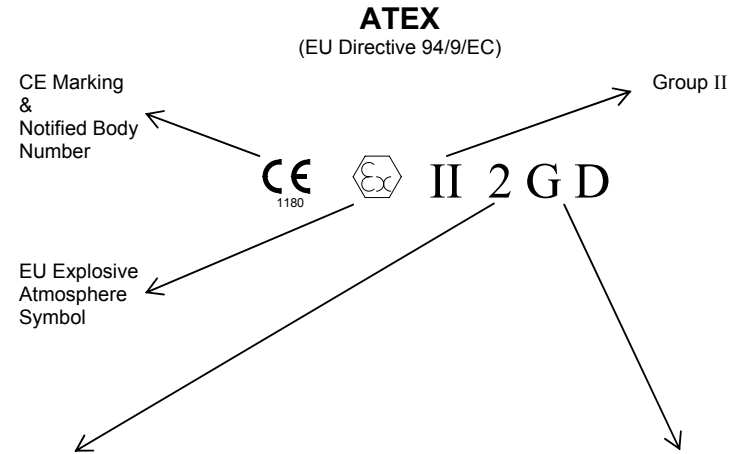

Equipment Category	Definition – ATEX Equipment Group II	Zone	
		G - gas	D - dust
1	- very high level of protection in which explosive atmosphere mixtures of air gases, vapours or mist are present continuously, for long periods	0	20
2	- high level of protection in which explosive atmosphere mixture of air and gases, vapours or mist are likely to occur	1	21
3	- normal level of protection in which explosive atmosphere mixtures of air and gases, vapours or mist are unlikely to occur and if it occurs it will exist only for a short period	2	22

These Flame Detectors are suitable for equipment categories 2 and 3, G or D.
Note: The detectors are not certified for category 1 areas, see 'IS' products.

Table 1 Equipment Categories and Type of Explosive Atmosphere (Group II)

CENELEC / IEC

Explosion Protection symbol

Ex d IIC T4 Gb

Equipment Protection Level Gas (EPL) [See EN60079-26]

Code	Type of Protection Code	Equipment Category
ia	Intrinsic safety	1
ib	Intrinsic safety	2
d	Flameproof	2
These Flame Detectors are approved 'd'.		

Table 2 Type of Protection Codes

Temperature Class Referred to ambient of -20°C to +40°C	Maximum Surface Temperature
T6	85°C
T5	100°C
T4	135°C
T3	200°C
T2	300°C
T1	450°C
Detectors approved to T4.	

Table 3 Temperature Classification

Gas Group	Representative Gas	Other Gases, Liquids, Vapours
IIC	Hydrogen	Acetylene, Carbon Disulphide
IIB	Ethylene	Diethyl ether, Tetrafluoroethylene
IIA	Methane	Butane, Methanol, Petroleum, Propane, Styrene
These Flame Detectors are approved IIC for listed gases in EN 60079-0.		

Table 4 Subdivisions of Group II Gases

Ex tb IIIC T135°C Db

Dust Protection Concept [See EN61241-1]

Dust Group	
IIIC	Conductive Dust
IIIB	Non-conductive Dust
IIIA	Combustible Flyings

Equipment Protection Level Dust (EPL) [See EN60079-26]
Maximum External Surface Temperature

Health and Safety at Work Act

In the UK all equipment must be installed and disposed of (as required) within the legislative requirements of the Health & Safety at Work Act 1974.

Installation

No modification should be made to the enclosure without reference to the manufacturer as unauthorised modification to an approved enclosure will invalidate the certificate/approval.

1. The enclosures are supplied with drilled and tapped entries. See enclosure drawing
2. The surface of the machined/threaded flamepaths between cover and body must be protected from scratches or damage during installation. Any such damage can destroy the validity of the enclosure.
3. Before the cover is refitted, the flamepath/threaded joint between cover and body must be thoroughly wiped clean of dirt, grit or other foreign substances, and then a thin coating of an approved form of non-setting grease applied to joint/threads. Ensure the gasket o-ring is free from damage.
4. Threaded covers must be screwed on to a minimum of 5 full threads of engagement and then locked in position with the locking screw provided.
5. All tapped entries must be fitted with an approved flameproof (Exd) device which is equivalent or superior to the gas group and temperature of the enclosure.
6. The enclosure should be mounted using the two rear M6 tapped holes.
7. Do not scratch the glass.
8. Glanding of cables should be as in Selection of Cable Gland section.

Selection of Cable Glands

Application of barrier glands certified and approved to meet EN 60079-14 for Thermo Plastic, Thermosetting and Elastomeric Cables. The external cables and glands used for high temperature application must be compatible with the temperature.

	Hazardous Area Type	Gland Method
1)	Zone 1, 2 Z1 & Z2 Hazardous areas requiring IIC apparatus	Exd Barrier Glands mandatory
2)	Zone 2 & Z2 Hazardous areas requiring IIA & IIB apparatus.	Any Exd Gland permitted

Table 5 Examples of barrier glands

Enclosure Details

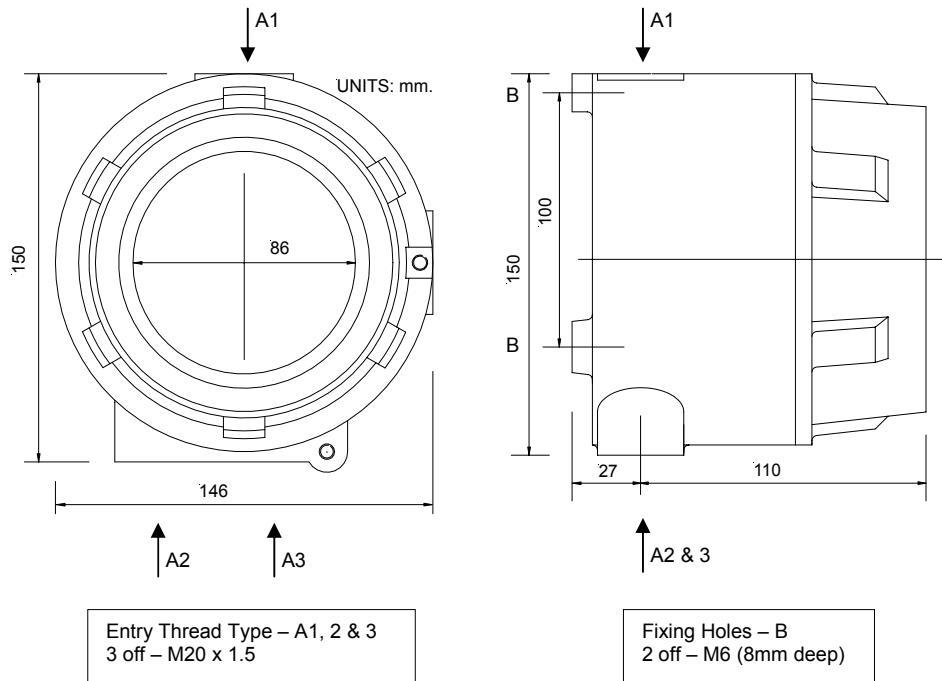

Flameproof Products

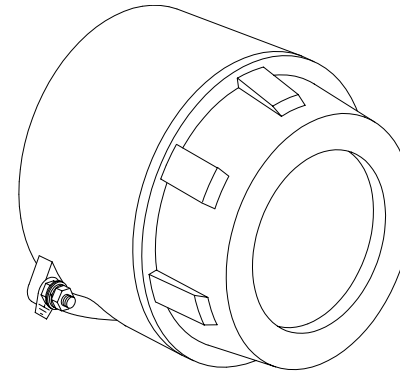

Flameproof Flame Detector
(Alloy Housing)
Fig. 1

The flame detectors respond to light emitted from flames during combustion. The detectors discriminate between flames and other light sources by responding only to low frequency flickering produced by flames (typically 1 to 15Hz). The detectors ignore fixed light sources and rapidly flickering illumination predominantly produced by lighting. The flame flicker techniques have the advantage of still allowing the detection of flames through a thin layer of oil, water vapour, ice or dust. This makes these detectors particularly useful in industrial applications.

Full details of the principles of operation, electrical description, and other detailed technical data are published in the products individual data sheet.

Technical Data

Mechanical

Housing Material: See figure 1	Copper Aluminium LM25	Free Alloy
Housing Colour:	Red	
Housing Dimension: (Excluding Mount)	Height = 150mm Width = 146mm Depth = 137mm	
Cable Gland Entries:	3 X 20mm	

Electrical

Supply In: Voltage Current Polarity sensitive	Terminals 1(+) & 2(-) 14 to 30Vdc 2 to 28mA See data sheet for detail
Optional Input: Voltage Current Polarity sensitive	Terminals 3(+) & 4(-) 14 to 30Vdc 40µA typ. @ 24V IN
Power Up Time:	2 seconds
Relays Contact Ratings: Voltage Current Power Resistive Loads Only	Terminals 5 to 8 30Vdc. Max. 1 Amp. Max. 30W Max.

Environmental

ATEX Approval Category	II 2 G D
CENELEC / IEC Marking	Ex d IIC T4 Gb Ex tb IIC T135°C Db (Zone 1, 21, 2 & 22)
Ambient Temperature Range: Also check detector data sheet.	Tamb -40°C to +125°C
Apparatus Certificate Numbers	Baseefa08ATEX0270 IECEx BAS08.0073
IP Rating	IP66

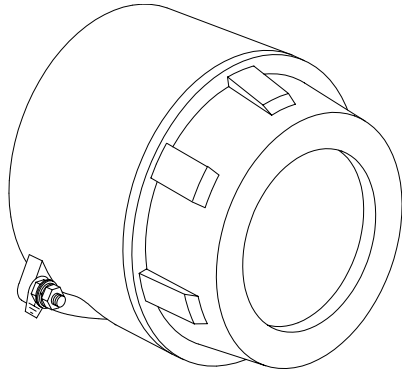

Flameproof Flame Detector
(Stainless Steel Housing)
Fig. 2

Technical Data

Mechanical

Housing Material: See figure 2	316 Stainless Steel
Housing Colour:	Natural
Housing Dimension: (Excluding Mounts)	Height = 150mm Width = 146mm Depth = 137mm
Cable Gland Entries:	3 X 20mm - typical

Electrical

Supply In: Voltage Current Polarity sensitive	Terminals 1(+) & 2(-) 14 to 30Vdc 2 to 28mA See data sheet for detail
Optional Input: Voltage Current Polarity sensitive	Terminals 3(+) & 4(-) 14 to 30Vdc 40µA typ. @ 24V IN
Power Up Time:	2 seconds
Relays Contact Ratings: Voltage Current Power Resistive Loads Only	Terminals 5 to 8 30Vdc. Max. 1 Amp. Max. 30W Max.

Environmental

ATEX Approval Category	 II 2 G D
CENELEC / IEC Marking	Ex d IIC T4 Gb Ex tb IIIC T135°C Db (Zone 1, 21, 2 & 22)
Ambient Temperature Range: <small>Also check detector data sheet.</small>	Tamb -40°C to +125°C
Apparatus Certificate Numbers	Baseefa08ATEX0270 IECEX BAS08.0073
IP Rating	IP66

System Design

Engineers familiar with codes of practice for hazardous area systems should only undertake the design of a flameproof fire detection system. In Europe the standard is EN 60079-0 (formally EN 50014), Electrical apparatus for potentially explosive atmospheres – General requirements.

The fire detector performance is the same as the standard non flameproof counterparts. Performance information given in standard product guides is therefore applicable to the flameproof range.

The Baseefa certification of the flameproof device enclosure covers their characteristics as components of a flameproof system. This indicates that the flame detectors can be used with a margin of safety in such systems.

Service & Repairs

1. Frequent inspection should be made. A schedule for the maintenance check should be determined by the environment and frequency of use but should be regular enough to ensure the detector continues to operate in the designed manner. It is recommended that it should be at least once a year.
2. External surfaces of the enclosure should be periodically cleaned to ensure dust deposits are not allowed to accumulate.
3. Check flamepath/threads on enclosure body and lid for signs of corrosion. If badly pitted, replace component.
4. All components that are replaced must be in accordance with the manufactures specification. Failure to use such components may invalidate the certification/approval on the enclosure and may make the enclosure dangerous.
5. After inspection and maintenance have been carried out, items 3 & 4 of the installation instructions should be adhered to when resealing the enclosure.

Servicing of the fire protection system should be carried out as recommended by the local regulation in force.